

BLOQUE B

BARRIO JARDIN LOS MANANTIALES

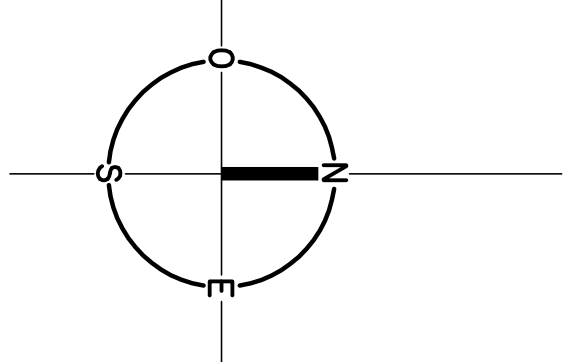

BLOQUE B
(136 UNIDADES)
LOS MANANTIALES
SUPERFICIE DEL BLOQUE = 68.010,00m²

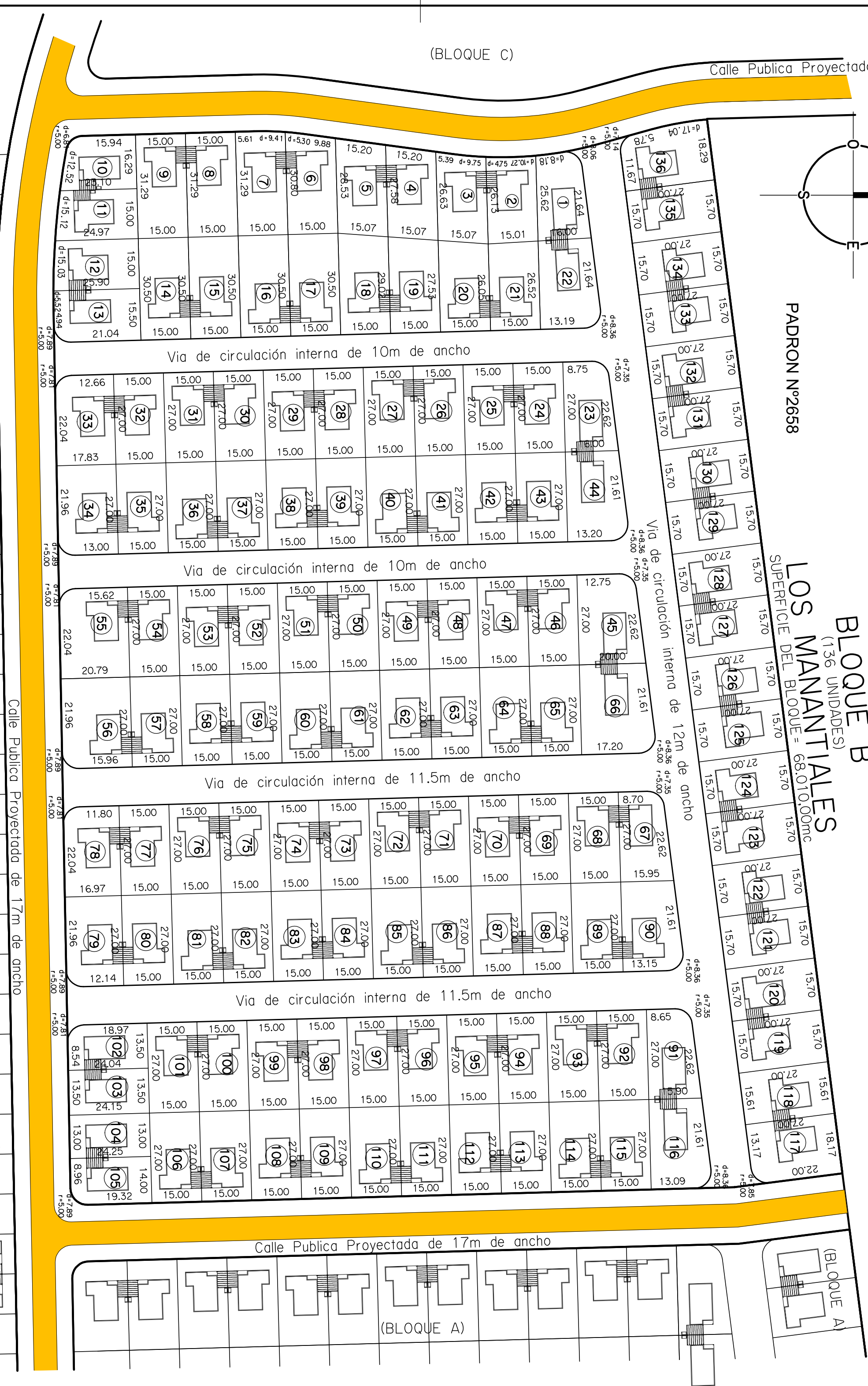

PADRON N°24343

PADRON N°24344

PADRON N°24345

PADRON N°24346

PADRON N°24347

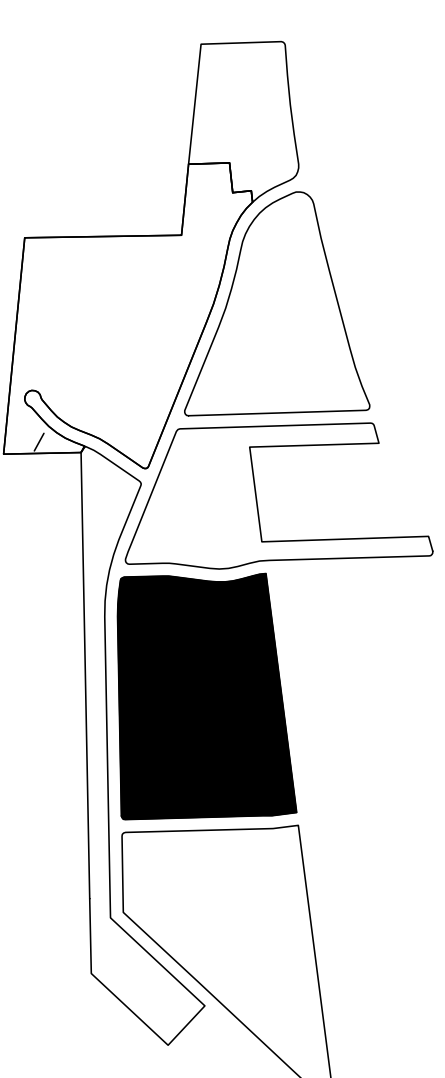

UBICACION

PLANILLA DE AREAS

BLOQUE	CASAS	AREA TOTAL
B LM	1	377,44
	2	385,53
	3	393,78
	4	406,57
	5	420,79
	6	445,87
	7	467,79
	8	469,30
	9	349,06
	10	361,70
	11	382,70
	12	397,78
	13	457,50
	14	457,50
	15	457,50
	16	457,50
	17	457,50
	18	446,37
	19	424,11
	20	401,85
	21	394,29
	22	458,27
	23	390,98
	24	405,00
	25	405,00
	26	405,00
	27	405,00
	28	405,00
	29	405,00
	30	405,00
	31	405,00
	32	405,00
	33	473,22
	34	478,74
	35	405,00
	36	405,00
	37	405,00
	38	405,00
	39	405,00
	40	405,00
	41	405,00
	42	405,00
	43	405,00
	44	498,98
	45	405,00
	46	405,00
	47	405,00
	48	405,00
	49	405,00
	50	405,00
	51	405,00
	52	405,00
	53	405,00
	54	405,00
	55	553,23
	56	558,75
	57	405,00
	58	405,00
	59	405,00
	60	405,00
	61	405,00
	62	405,00
	63	405,00
	64	405,00
	65	405,00
	66	570,04
	67	389,61
	68	405,00

Los areas indicadas aqui corresponden a la totalidad de la superficie relacionada a cada una de las futuras unidades (Es la suma del area individual, muros, parrilla, pérgola, etc., en la futura Propiedad Horizontal)

PLANILLA DE AREAS

BLOQUE	CASAS	AREA TOTAL
B LM	69	405,00
	70	405,00
	71	405,00
	72	405,00
	73	405,00
	74	405,00
	75	405,00
	76	405,00
	77	405,00
	78	450,00
	79	455,53
	80	405,00
	81	405,00
	82	405,00
	83	405,00
	84	405,00
	85	405,00
	86	405,00
	87	405,00
	88	405,00
	89	405,00
	90	460,68
	91	388,25
	92	405,00
	93	405,00
	94	405,00
	95	405,00
	96	405,00
	97	405,00
	98	405,00
	99	405,00
	100	405,00
	101	405,00
	102	318,54
	103	325,24
	104	314,54
	105	334,76
	106	405,00
	107	405,00
	108	405,00
	109	405,00
	110	405,00
	111	405,00
	112	405,00
	113	405,00
	114	405,00
	115	405,00
	116	459,31
	117	485,15
	118	421,57
	119	423,90
	120	423,90
	121	423,90
	122	423,90
	123	423,90
	124	423,90
	125	423,90
	126	423,90
	127	423,90
	128	423,90
	129	423,90
	130	423,90
	131	423,90
	132	423,90
	133	423,90
	134	423,90
	135	423,90
	136	471,59
	Total	56529,55

Los areas indicadas aqui corresponden a la totalidad de la superficie relacionada a cada una de las futuras unidades (Es la suma del area individual, muros, parrilla, pérgola, etc., en la futura Propiedad Horizontal)

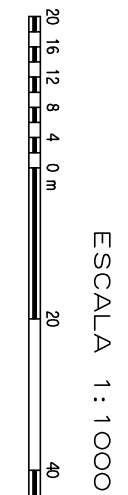

ESCALA 1 : 1000

(de ambos Planillos)